

A STEREO CONDENSER

By W. M. DEBENHAM, D. P. ROBINSON and D. W. STEBBINGS

IN these articles we hope to describe in some detail the theory and construction of a stereo condenser microphone, with polar (directional) characteristics which can be changed at will from a remote position, if necessary during recording. The monophonic version is shown completed in fig. 1.

For some time condenser microphones have been first choice for the highest quality work by world-wide broadcasting organisations. Apart from the excellent and extended frequency response, coupled with superlative transient response, they are not delicate instruments. We find that the microphone to be described will easily withstand a drop from waist height without any effect on performance. Closely matched frequency responses are essential for stereo work, as those who have tried to listen to stereo with dissimilar loudspeakers will know only too well. A few dBs difference can be overlooked in mono, but our ears refuse to ignore it in stereo. We have found the phase response to be excellent, since by addition of the two outputs in antiphase when fed from a common source, the combined output falls by 30 dB, representing a phase response accurate to about six degrees.

Variable Characteristics

With a double diaphragm system, such as the one to be described, there is the facility of switched polar response, and the three basic patterns available, omnidirectional, cardioid, and figure-of-eight (*omni*, *cardioid* and *eight* for short), can be changed during pick-up without switching-noise appearing in the signal output. This is a most useful facility; for the amateur the *cardioid* is almost essential when recording a large orchestra to prevent interference from audience or traffic noises, whilst for small-group recordings the other characteristics are more useful when, for example, performers can be seated near to the microphone.

The principle of the condenser microphone is well known and has been described elsewhere (see p. 622, February *Hi-Fi News*). But to indicate a few points of interest it is instructive to write down the expression for the sensitivity, which can easily be derived from the basic equation $C = Q/V$. Then $dV = V/C$ and $dC = V/x dx$, where x is the separation of the capacitor plates. An interesting point is that the expression for the sensitivity is independent of the capsule area, this being determined by the acoustic requirements of the *cardioid*. V represents the voltage on the capacitor, and it can be seen that for maximum sensitivity it should be large, with the smallest possible plate separation; a compromise is effected here, since arcing between the plates must not occur. In our case a polarising voltage of 50 V is used, and a separation of 1.5 thou., which gives a capacity of about 50 pF. This value will be used in calculations for the head amplifier to be discussed in the next article.

The two types of microphones most commonly met are the *omni* and *eight*. The first type is pressure operated, and is usually a device that measures the air pressure by comparison with its internal pressure,

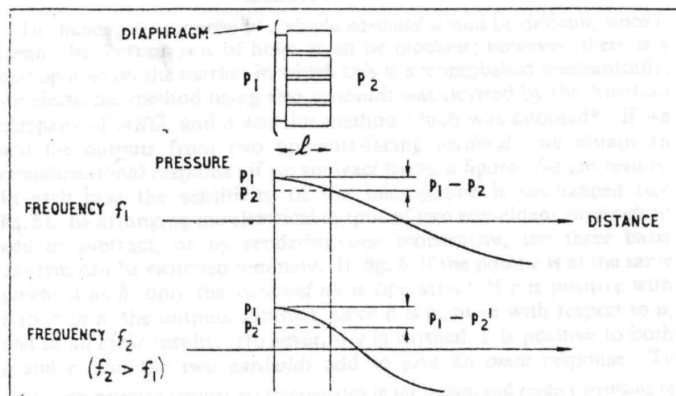

Fig. 2. Pressure difference between front and back varies with frequency

acting in fact like an aneroid barometer. If the condenser diaphragm is stretched over a totally enclosed space, it will be depressed equally for pressure waves arriving from any direction. By making the volume of enclosed air small, the internal pressure for a given deflection of the diaphragm is increased over that when the volume is large, and therefore the microphone is less sensitive because the instantaneous pressure difference between inside and outside is lowered. At the same time the resonant frequency of the diaphragm is raised. This is easily demonstrated by stretching a thin polythene bag over the top of a milk bottle, tapping it with a finger and listening to the rising note as water is added

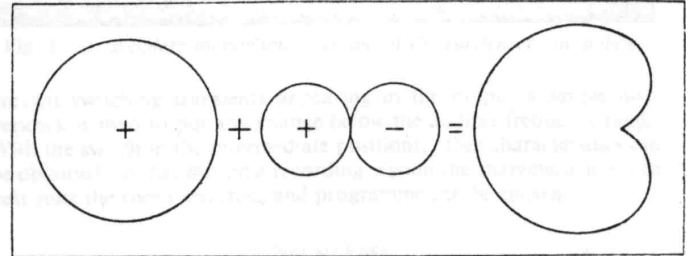

Fig. 3. Omni-directional plus figure-of-eight produces a cardioid

to the bottle. Notice also that the note continues for some time after the tap is given, or in electrical terms the 'Q' of the circuit is high. This represents, in the case of the microphone, an unwanted signal after the initial output. To remove this we must critically damp the diaphragm, and we do this by adding 'resistance' to the circuit. Acoustic 'circuits' can be drawn with electrical equivalents (see p. 71, *Acoustical Engineering* by H. F. Olson).

Velocity Microphones

Now let us consider the pressure-gradient or velocity microphone. In fig. 2 a microphone is shown in a sine-wave pressure field, with the back of the diaphragm also open to the air. The pressure difference, $P_1 - P_2$, is the pressure which moves the diaphragm; the system is comparing the pressure difference between two points in space. Since, for sound waves of the same amplitude but decreasing frequency, the pressure difference between two points a distance l apart will fall by 6 dB per octave, we have to load the diaphragm in such a way as to give a flat response. This is achieved by controlling the mass of the diaphragm and of the enclosed air, since the time taken for the rate-of-change of position, or acceleration, of the diaphragm will limit the output and will

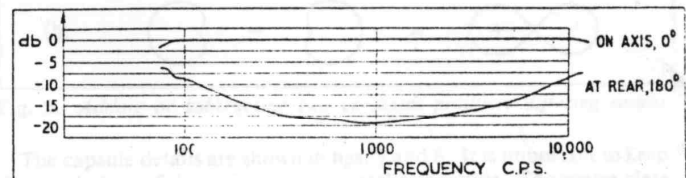

Fig. 4. A cardioid response becomes imperfect at the frequency extremes

cause a change in sensitivity of 6 dB per octave. This can be explained by considering that the output is proportional to the diaphragm displacement, and since a 'massy' diaphragm will take time to accelerate and move to a given position, the longer the driving force acts on the diaphragm the further it will move, to a first approximation. Thus doubling the frequency of the force will halve its time of action and so the displacement halves, which means the output falls by 6 dB. The net result of the two conditions is to produce a flat frequency response. The remarks made earlier on damping the system with acoustic resistance still apply, and it can be seen that the sensitivity is controlled jointly by the acoustic mass and the acoustic resistance.

Any wave-front transverse to the capsule will contain no lateral pressure difference, and so should produce no output in the velocity microphone. But if the wavelength of the highest frequency to be considered approaches the diameter of the capsule ($\lambda = 0.66$ in. for 20 Kc/s), differential pressures will be set up along the diameter. For this condition to produce no output, there must be no movement of air from high to low pressure regions along a diameter. In the microphone, the spacing of the diaphragm from the electrode is typically 0.002 in.; this gives a high longitudinal impedance, which in turn means there is negligible air movement. This is demonstrated in the polar response curve to be shown in the next article.

There are several ways of considering the *cardioid*, and one of the simplest is to regard it as the addition of *eight* and *omni* responses of equal sensitivity. This addition can occur electrically by combining the outputs of two such microphones placed in close proximity, usually in the same casing, or mechanically as in the condenser microphone: this addition is shown in fig. 3. The responses cancel at the back of the capsule due to the phase inversion of this half of the *eight* response. It is clear that the *cardioid* will be maintained only while there are no unwanted phase shifts or amplitude variations in the directional responses. In fact both such effects occur, as we would

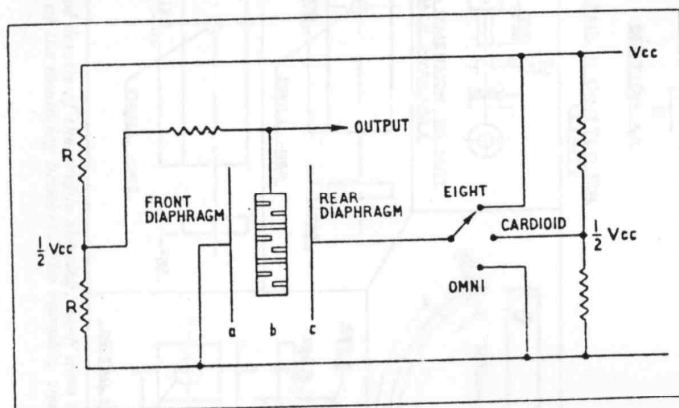

Fig. 6. Electrical circuit for changing the directional characteristics

expect from any L/C/R circuit, which means that the polar response of the *cardioid* is impaired at the extremes of the audio range, as shown in fig. 4. To make a microphone where the addition occurs automatically, holes must be drilled through the backplate of the *omni* capsule and adjustments made to the ratio of these and the damping holes until the perfect *cardioid* results. To ensure the diaphragm is evenly loaded, a large number of fine holes are used; in practice a No. 60 (1 mm) drill is used for the damping holes, and a No. 70 (0.7 mm) for the perforations (wastage is usually quite high on these very fine drills!). Fig. 7 gives a detailed plan of the positions of the various holes in the capsule.

Electrical Control

To change the response of a single *cardioid* would be difficult, since it means that certain sets of holes must be blocked; however, there is a microphone on the market in which this is accomplished mechanically. An electronic method using two *cardioids* was devised by the Austrian company of *AKG*, and it was this method which was adopted*. If we add the outputs from two opposite-facing *cardioids*, we obtain an omnidirectional response; if we subtract them, a figure-of-eight results. In each case the sensitivity of the microphone is unchanged (see fig. 5). By arranging the electrical output of two coincident *cardioids* to add or subtract, or by rendering one inoperative, the three basic patterns can be switched remotely. In fig. 6, if the point *c* is at the same potential as *b*, only the *cardioid* *ab* is operative. If *c* is positive with respect to *b*, the outputs subtract, since *b* is positive with respect to *a*, and so an *eight* results. However, if *c* is earthed, *b* is positive to both *a* and *c*, and the two *cardioids* add to give an *omni* response. To

* Certain patented features are incorporated in the design, and readers intending to build the microphone are advised to make enquiries about licensing.

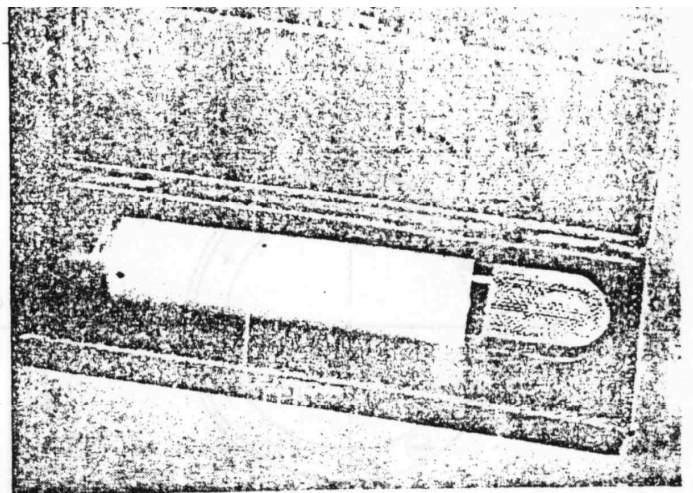

Fig. 1. A complete monophonic version of the condenser microphone

prevent switching transients appearing in the output a simple filter network is used to put any change below the audible frequency range. With the switch in the intermediate positions, other characteristics can be obtained, so that during a recording session the characteristic which best suits the room acoustics and programme can be chosen.

Not so Easy

In practice all is not as easy as it might appear, since it is not possible either to arrange the sensitivity and acoustic loading of the two *cardioids* to be exactly the same, or to obtain a perfect *cardioid* in each case. This produces an effect of a change in frequency response as the switch is moved from one extreme to the other. In the very first experimental capsule we made, a swing of 10 dB at the bass and treble ends was noted, giving a pronounced change in the output. Commercial manufacturers overcome this by inserting 4 μ (1/16th of a thou.) shims between the capsule halves, retesting after each addition until the response varies by less than 1 dB, which in effect is varying the acoustic resistance to affect the *eight* component of the individual *cardioid* more than the *omni*. Clearly this technique is impracticable for the amateur, even if 4 μ shims were generally available, since facilities for accurate testing of microphones are rare. By redesigning our experimental capsule, and by very careful machining and drilling, we have matched the capsules to give less than 2 dB change in sensitivity and response on switching; the diagrams are for this capsule.

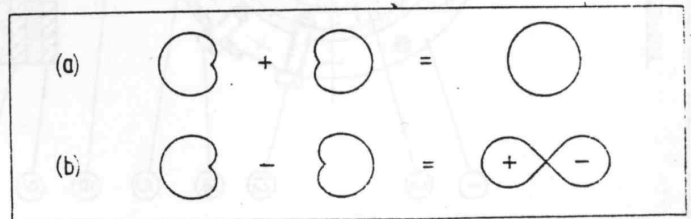

Fig. 5. Adding or subtracting two *cardioids* produces differing results

The capsule details are shown in figs. 7 and 8. It is important to keep the two halves of the unit as symmetrical as possible. The centre plate is made from aluminium alloy, held in a Perspex ring which has a shoulder to stretch the thin diaphragm material across the centre section. This shoulder must be of very high insulation resistance as well as being mechanically strong, and the Perspex admirably satisfies the two criteria.

The construction of the capsule is shown in sufficient detail for fig. 7 to be used as a working drawing, but it may be of some help to outline the main steps involved in the manufacture. The first operation is to bore a 1 in. hole in a roughly cut Perspex disc of about 1 1/2 in. diameter, and to fit to this an accurately turned dural bar; Araldite was used to form a permanent join. When the glue has set, the Perspex is turned

(continued on page 243, figs. 8 and 9 on page 241)

to the final diameter and both ends of the capsule faced. All the holes are now drilled, and those in the Perspex tapped to take the diaphragm fixing screws. The next step is to cut the $1\frac{1}{2}$ thou. clearance ring around the capsule, to a depth of 0.05 in. using a special tool ground for this work. This guard ring ensures that any small wrinkles in the diaphragm at its edge do not short to the central electrode. Since this forms a considerable addition to the cavity volume it must be accurately machined to keep the final results as calculated. Following this, the holes for the atmospheric vent and for the mounting bracket are drilled, and that for the connector to the centre is drilled and tapped.

The Correct Profile

The capsule is then reinserted in the lathe, and after testing for correct siting with a dial gauge, the faces are turned to the correct profile shown in fig. 7. A $\frac{1}{4}$ thou. is first taken off the whole surface, and then $1\frac{1}{2}$ thou. off the dural only. The tool must always be wound on in this operation, and never backwards, to prevent any backlash error. It is also best to take this final cut in one; this lessens the likelihood of tool chatter and consequent ridges. Finally, the outside half of the Perspex ring is turned down slightly to ensure that the diaphragm is supported at the inner edge. The final operation is to polish the centre electrode with rouge, followed by a thorough clean. This we have found to be one of the most difficult operations, and an apparently perfect capsule will arc when assembled, and on reopening will yield a surprising amount of metal waste. So that the assembly may be opened, the diaphragm is made removable by gluing the thin material (Mylar, flashed with aluminium) to a ring. We found the best way to stretch the material was to place it over the capsule clamped between two rings of slightly larger diameter. The underside of the diaphragm ring is

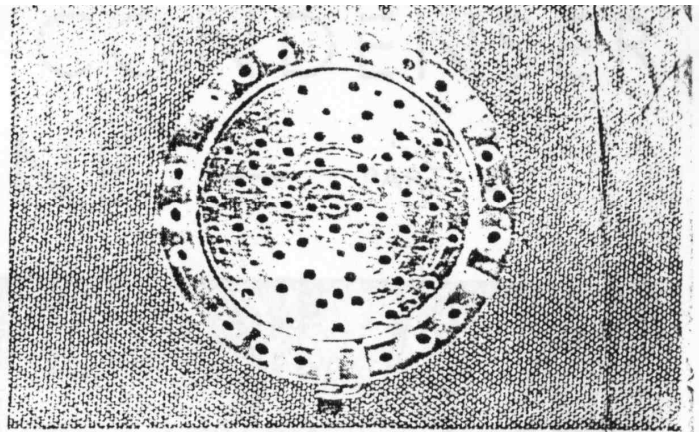

The finished capsule in unpolished state and with the diaphragm removed

lightly coated with Araldite and placed on the tight material; holes are made with a scribe and the ring is clamped down on the Perspex surround; the surplus material can then be trimmed away, and when set the ring and diaphragm can be removed together. Once clean, it is not necessary to remove the rings at all, and the instrument is extremely reliable.

Mounting Details

The mounting bracket is shown in the various views in fig. 9 and is very simple, providing an anti-microphonic support. This screws to the top of the main assembly, which, together with the electronics involved in the head amplifier and the stereo arrangements, will be described in next month's article.

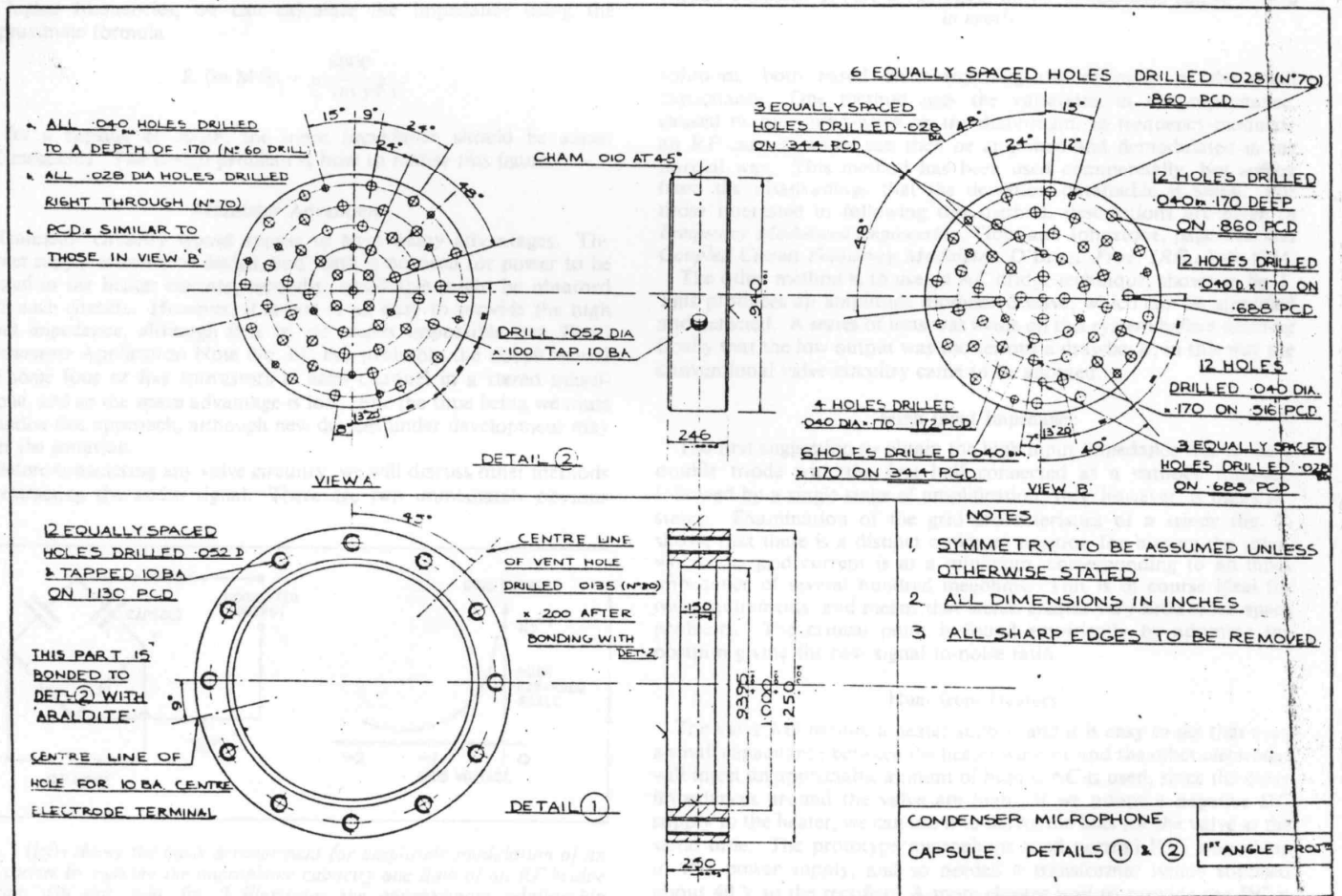

Fig. 7. Precise details of the holes to be drilled in the capsule; this is a tricky job which must be performed accurately.

A STEREO CONDENSER MICROPHONE — PART 2

BY W. M. DEBENHAM, D. P. ROBINSON
and D. W. STEBBINGS

IN the first article we outlined the theoretical and practical considerations in the design of the capsule assembly; in this second we will discuss the requirements of the amplifier to follow the capsule, and the control arrangements necessary to obtain the variable polar characteristics which are a particular feature of the design.

Referring to the first article, we showed that the capacitance of the cell is in the order of 60 pF, which means that any cable connected between the cell and, say, a tape recorder will seriously attenuate the signal; even the best cables will have a capacitance of about 20 pF per foot. Secondly, the impedance of the device is high, so that the cable is prone to hum pick-up. On both these counts it is desirable to have the first stage of amplification as close to the capsule as possible.

Let us consider first the normal R/C network for coupling the capsule to the amplifier. To maintain the low frequency response, a high input impedance must be provided. If we take 30 c/s as the point at which the output of the amplifier is -3 dB relative to the output at higher frequencies, we can calculate the impedance using the approximate formula

$$R \text{ (in } M\Omega) = \frac{6000}{C \text{ (in pF)}}$$

or for a capsule of 50 pF, the input impedance should be about 120 megohms. The design problem is how to realise this figure.

Transistor Advantages

Transistor circuitry would appear to have many advantages. The power supply is easier to design, and there is no need for power to be wasted in the heater circuits; secondly, small size might be obtained with such circuits. However, it is not at all easy to provide the high input impedance, although it is by no means impossible (see *Texas Instruments Application Note No. 6*); but probably the circuit would use some four or five transistors in each channel in a stereo microphone, and so the space advantage is lost. For the time being we must abandon this approach, although new devices under development may alter the situation.

Before considering any valve circuitry, we will discuss other methods of extracting the audio signal. There are two immediately obvious

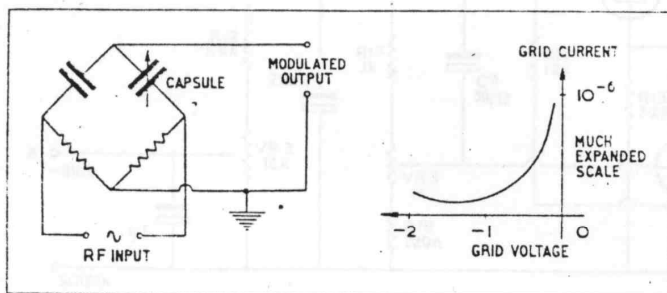

Fig. 1 (left) shows the basic arrangement for amplitude modulation of an RF carrier by making the microphone capacity one limb of an RF bridge circuit. On the right, fig. 2 illustrates the approximate relationship between grid current and negative bias in a triode, showing that there is an optimum bias for maximum input resistance

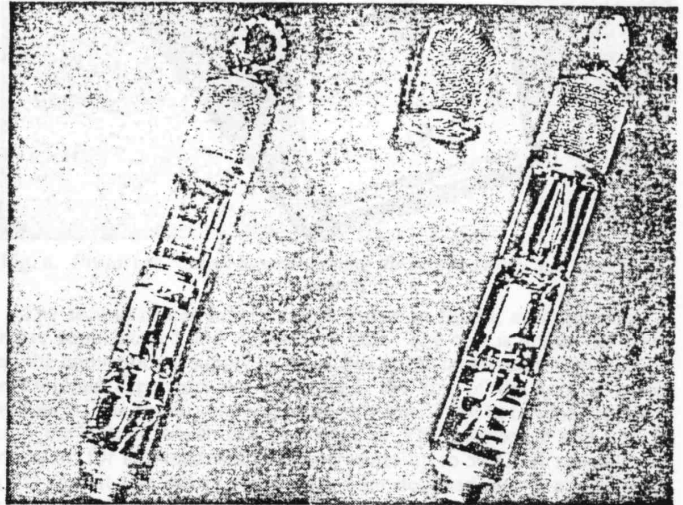

Fig. 7. Two views of the completed head assembly, each with the upper capsule exposed. If care is exercised, all the components can be packed in neatly

solutions, both based on overcoming the difficulty of the small capacitance. One method uses the variations in the capacitance, caused by the sound-wave on the diaphragm, to frequency-modulate an RF carrier, which can then be amplified and demodulated in the normal way. This method has been used commercially, but suffers from the disadvantage that the deviation obtainable is small. For those interested in following this method, descriptions are given in *Frequency Modulated Engineering*, Tibbs and Johnstone, page 246, and *Coupled Circuit Frequency Modulator*, O'Brien, *Proc. IRE.*, July 1944.

The other method is to use an AC bridge technique, shown in fig. 1. This produces an amplitude modulated wave, which can be amplified and detected. A series of tests was made on this system before deciding finally that the low output was too serious a drawback; in this way the conventional valve circuitry came to be adopted.

High Input Impedance

The first suggestion to obtain the high input impedance was to use a double triode with the first half connected as a cathode follower, followed by a single stage of amplification; this, however, is bulky for stereo. Examination of the grid characteristics of a triode (fig. 2) shows that there is a distinct optimum position for biasing the valve, where the grid current is at a minimum, corresponding to an input impedance of several hundred megohms. This is of course ideal for our requirements, and means that stereo creates very little extra space problems. The critical point is found empirically by adopting the position giving the best signal-to-noise ratio.

Hum from Heaters

The valve will require a heater supply, and it is easy to see that even a small capacitance between the heater winding and the other electrodes will inject an appreciable amount of hum if AC is used, since the other impedances around the valve are high. If we adopt a negative DC supply to the heater, we can use it to derive the bias for the valve at the same time. The prototype microphone used normal R/C smoothing in this power supply, and so needed a transformer which supplied about 40 V to the rectifier. A more elegant way to provide the DC is

(continued on page 341)

to use a transistor series regulator circuit, outlined in fig. 3, which gives a ripple-free output without dissipating power unnecessarily in resistors. The output remains constant at the predetermined value, set by the potentiometer, independent of the current drawn—provided, of course, this never exceeds the maximum rating for the circuit. Here the transformer need supply only 10 V AC to the rectifiers.

Conventional Choice

However, we have finalised with the more conventional unit shown in fig. 4. Both sections are straightforward units. The LT is derived from a 40 V, 500 mA winding on the transformer by bridge rectification, and uses two stages of smoothing (VR1/C6, R13/C5), with C7 as the reservoir capacitor. R10 protects the rectifiers during switch-on. The rectifiers used, both here and in the HT unit, are Ferranti silicon diodes type ZS74. With this system the voltage at the output could be about 50 V (were not the zener diode included) if the microphone was not plugged into the cable. Should connection be made after switching on, this voltage would be applied to the cold filament of the valve with dramatic and disastrous results. Zener OAZ224 is added to keep the output at a maximum of 7.2 V even at the end of tolerance of the diode. VR1 is used to set the output at 6.3 V under load conditions. Across this supply are R12 and VR2 which set the bias to the valve, with C4 providing additional decoupling at the cable end.

Less Current Required

The HT supply is simpler, as the current required is much less; this supply should be in the order of 100 V. Here again extensive smoothing is used. R5-8 form an accurate potential divider to set-up the conditions for the variable characteristics; high stability 2% resistors are used in this chain. The selected voltage passes to the network R9/C3 which prevents any switch-clicks from appearing in the output, to enable the characteristics to be altered on programme if desired.

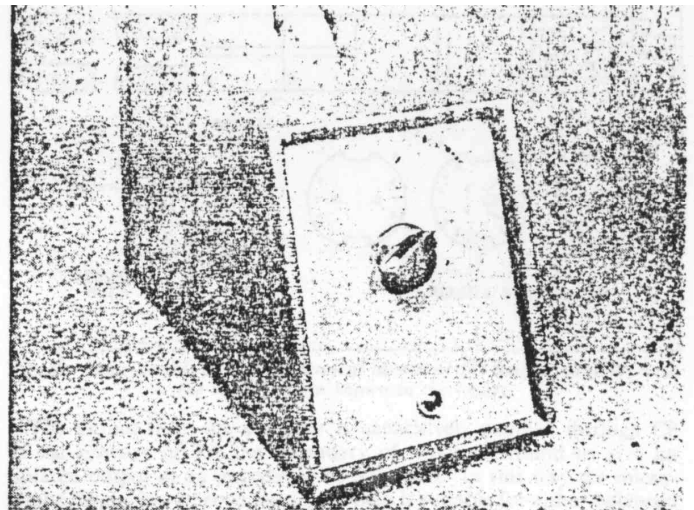

Fig. 6. Prototype control box containing the power supply and directional control

The second heater supply unit is shown in fig. 3a, and represents a more sophisticated and satisfactory unit. The cost is about the same as the conventional supply of fig. 4, but as the large-value high-voltage electrolytic capacitors are eliminated, the size of the unit is much reduced. The ripple voltage is extremely low, 2 mV at full load (0.5 A), and the output, which can be varied by VR3 between 5 and 8 V, is constant for any load and at temperatures up to 50°C. A transformer (T2) to suit this power supply has been designed and is available as type N360/2 from Forrest Transformers Ltd., 349 Haslucks Green Road, Shirley, Solihull, Warwickshire.

(continued on page 343)

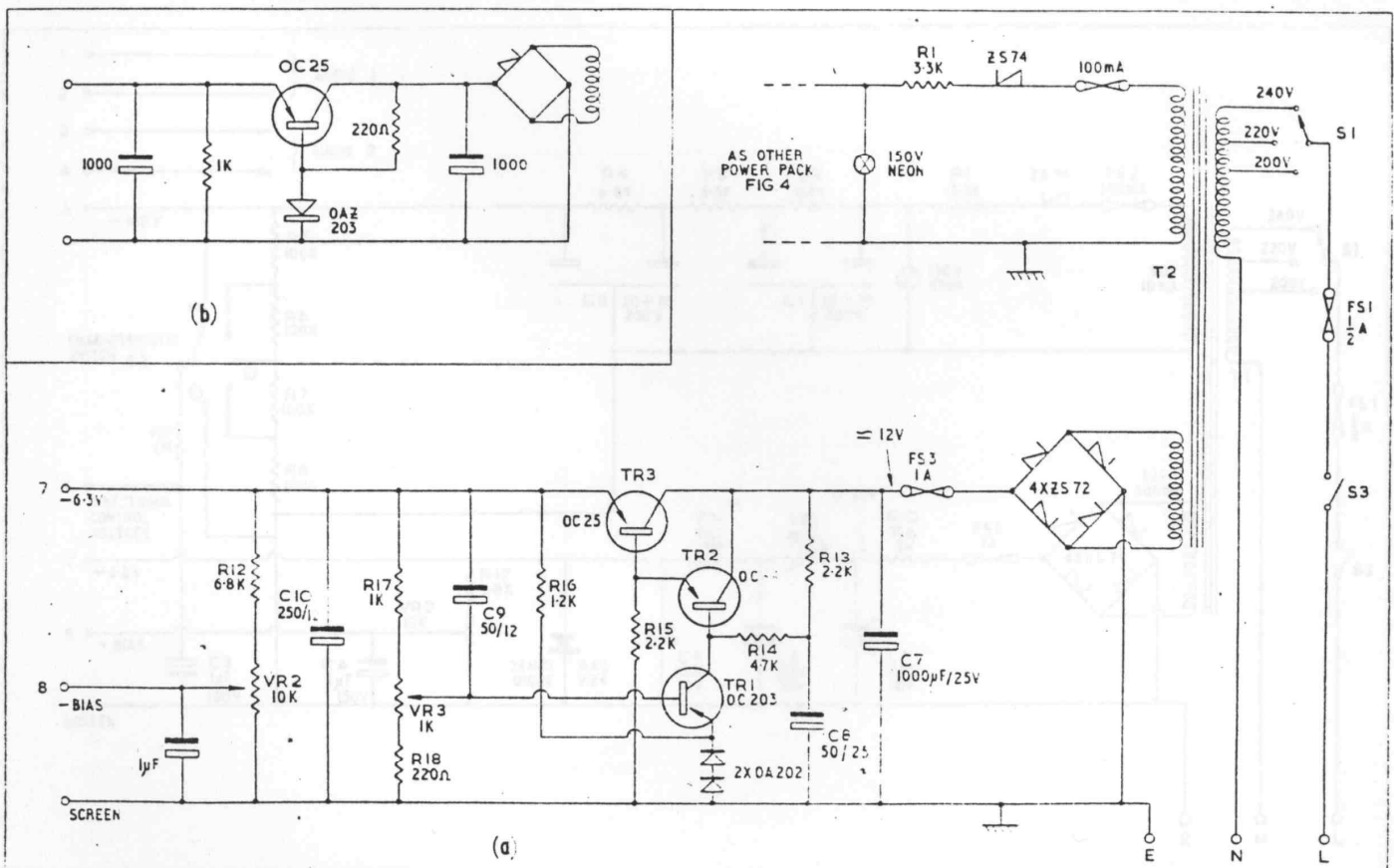

Fig. 3. The main circuit (a) shows a sophisticated transistorised stabilising arrangement for the DC heater supply, while the insert (b) is a simpler but less effective circuit.

The transformer output is rectified in the four-diode bridge, with C7 acting as the reservoir, and this DC voltage is the 'HT' supply for the DC amplifier which follows. In describing the action of this amplifier, it is easier to start at the output and work back to the input: a small fraction of the output is tapped by VR3 and applied directly to the base of TR1, whose emitter is held at a constant voltage equal to the forward drop across the two silicon diodes; R16 ensures there is always a steady current in these diodes. TR1 is a silicon transistor to ensure a low drift of output voltage with temperature. The output from this stage is directly coupled to the base of TR2, which, together with TR3, forms a compound emitter-follower. Thus the voltage at the collector of TR1 is the output voltage, neglecting the two base/emitter voltages of TR2 and 3. Should there be any ripple at the output, this is amplified by TR1 and applied in anti-phase to the output, thus cancelling the original ripple. HT supplies in this power supply are derived in exactly the same way as in fig. 4.

A Simpler Circuit

We also considered the simple circuit shown in fig. 3b, but decided against this for its high ripple, some 60 mV, and also for the inability to vary the output voltage easily.

All the supplies, from either power circuit, are taken via an eight-way screened cable to the microphone itself, whose circuit is shown in fig. 5. The voltage on the two centre electrodes is derived from the divider R16/17, which comprises 2% resistors so the voltage at their junction is accurately the same as that at the join of R6/7 (fig. 4), to give an effective cardioid from each capsule, as explained last month. R15 isolates the cell, whose output passes to the grid of the valve via C10, which must be a polystyrene type or similar to ensure extremely low leakage. Bias is applied through R14, and is decoupled at the microphone by R21/C12. In the same way, the switched polar voltage is decoupled by R18/C11. The valve is a 12AY7, or 6072, chosen for the low values of noise, microphony, and inter-electrode capacity.

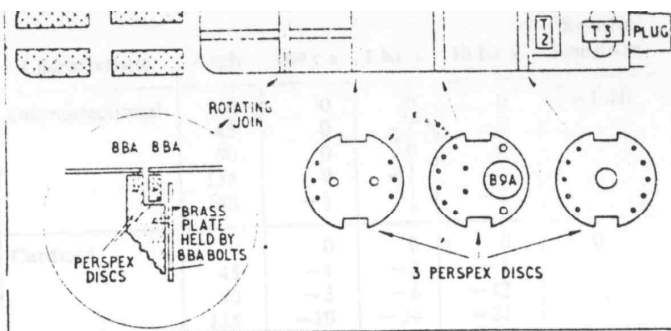

Fig. 8. Basic details of the mechanical layout of the head assembly, with the rotating joint shown in the insert

The output from the amplifier is capacitively coupled through C8 to the primary of T3, the secondary of which is wound to give an isolated output at an impedance of 600 ohms. In this way the microphone gives a low impedance drive which is suitable for either balanced or unbalanced lines. A suitable transformer for T3 and T4 is type 1872-48, by Drake Transformers Ltd., Billericay, Essex.

Construction of the control box is straightforward, and provided the transformer is kept away from the audio leads, there are no restrictions on the layout. Fig. 6 shows the prototype box, and fig. 7 shows the assembly of the microphone itself. (The authors would like to thank Malcolm Stewart for his excellent painstaking work in preparing the photographs used in these articles.) The bases of the structure are the three 1/2-in.-thick Perspex discs supported by two brass strips, all of which fit neatly inside a dural tube, which in our case was just under 1 1/2 in. internal diameter.

Fig. 8 illustrates how the components fit together; the top compartment takes R15, R18, R22, C10, C11, C13 and the valve, with the

(continued on page 345)

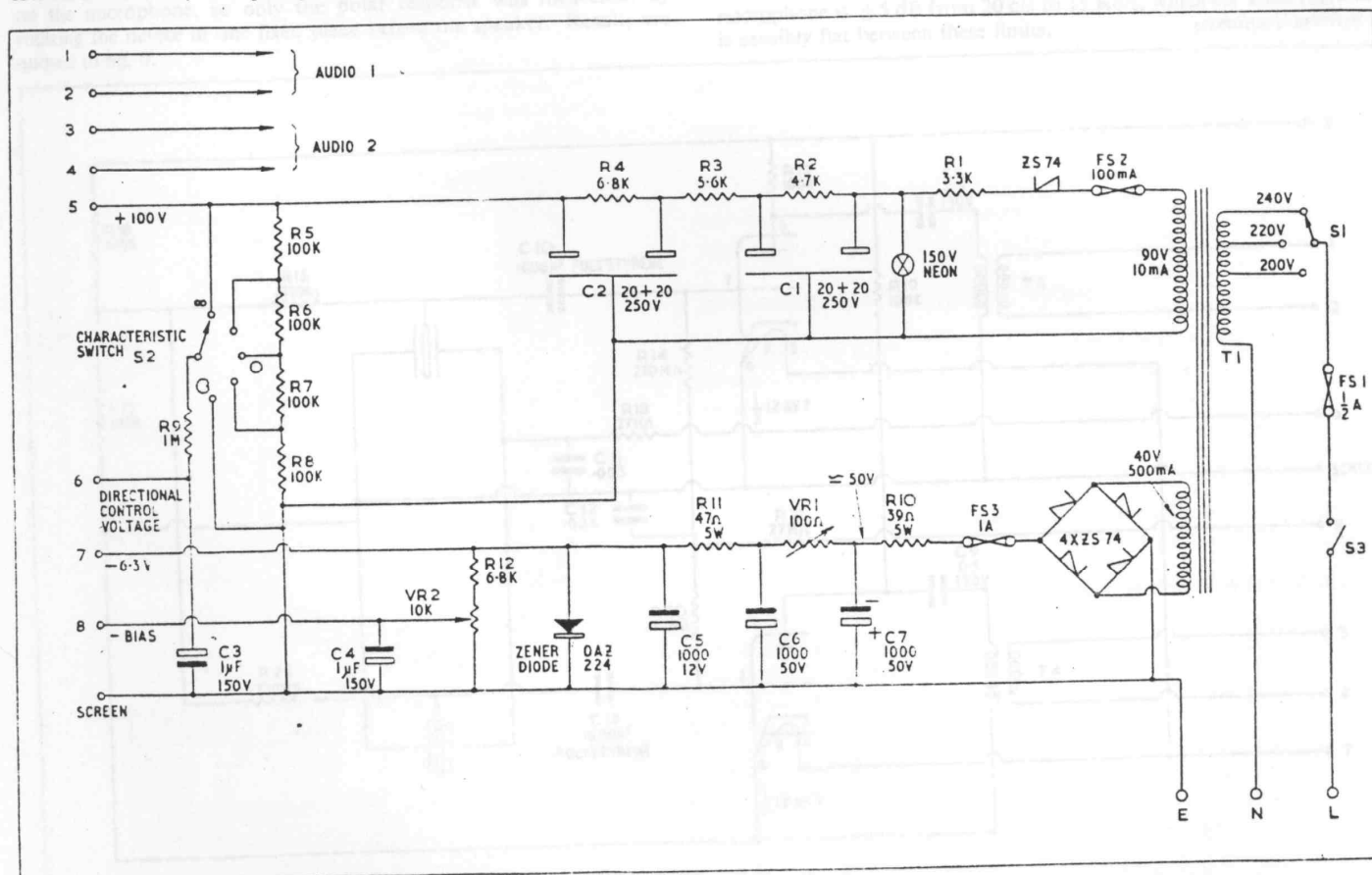

Fig. 4. The power supply circuit actually used in the prototype. This is housed in the control box shown in fig. 6

CONDENSER MICROPHONE—(continued)

middle disc having the hole for the valve holder, which is eccentrically mounted for easy removal and to allow room for the large resistors around it. The valve holder is a PTFE low-loss type, and should be mounted in some sort of an anti-microphonic mount. The remaining components are soldered between the discs on tags made by forcing hot wire into slightly undersized holes drilled in the Perspex. The base of the microphone is an aluminium turning, with an internally cut thread to take the multiway plug which, paradoxically, was one of the most difficult components to find. Eventually we discovered a supply of Plessey 12-way plugs and sockets on the surplus market. These plugs have the added advantage of a locking ring which prevents any accidental disconnection. Finally, the two transformers are mounted in the base at right angles to each other to keep crosstalk to a minimum.

The gauze top was made by first constructing the two upper frameworks from brass strip, silver-soldered together. The top part can be rotated relative to the bottom by an angle of 160° , to change the stereo angle if required, by using a simple sliding arrangement. Then four pieces of gauze were pressed into shape over wooden forms and soft-soldered into the brass frame. The whole assembly was then chrome-plated, which improved the appearance considerably. There are many small plating firms willing to carry out such work.

Finally, the performance figures. Our first tests naturally were subjective—live music of differing kinds was recorded, with gratifying results. All the usual attributes of a condenser microphone were present: the sound was exceptionally clean, and the clarity of the brass and percussion in a jazz recording were matched by the response at the extreme lower frequencies in a recording of an organ. However, after the first field trials were over, more scientific tests were made. The first of these was a very simple test with a loudspeaker as a source, in the open air to approximate to free space conditions. The loudspeaker response was not good enough for use in the frequency response tests on the microphone, so only the polar response was measured, by rotating the device in one fixed place before the speaker. Results are quoted in fig. 9.

Characteristic	Angle	100 c/s	1 Kc/s	10 Kc/s	Relative Sensitivity
Omnidirectional	0	0	0	0	-1 dB
	45	0	-1	-2	
	90	0	0	0	
	135	0	+1	-1	
	180	+1	-1	-2	
Cardioid	0	0	0	0	0
	45	-1	-2	-8	
	90	-3	-6	-12	
	135	-10	-24	-22	
	180	-12	-23	-15	
Figure of Eight	0	0	0	0	-1
	45	-3	-3	-6	
	90	-25	-25	-20	
	135	-3	-2	-10	
	180	0	0	-3	

Fig. 9. Table showing the measured variations of response at various angles for the three directional conditions

Analysis of these results shows that the basic patterns are produced, although, never being satisfied, we would like to see an improvement. The cardioid acceptance angle is sensibly wide, and the rejection at the sides in the figure of eight position is excellent. By individual tuning of the capsules, an improvement to the low frequency cardioid results, the extent of this depending on your time and patience.

For the second tests we were fortunate in being able to use a B & K automatic recorder to measure the frequency response. This was calibrated accurately, so that the response curves in fig. 10 represent the actual response of the microphone. From fig. 10 we can see the microphone is ± 5 dB from 20 c/s to 15 Kc/s, which for a microphone is sensibly flat between these limits. (continued overleaf)

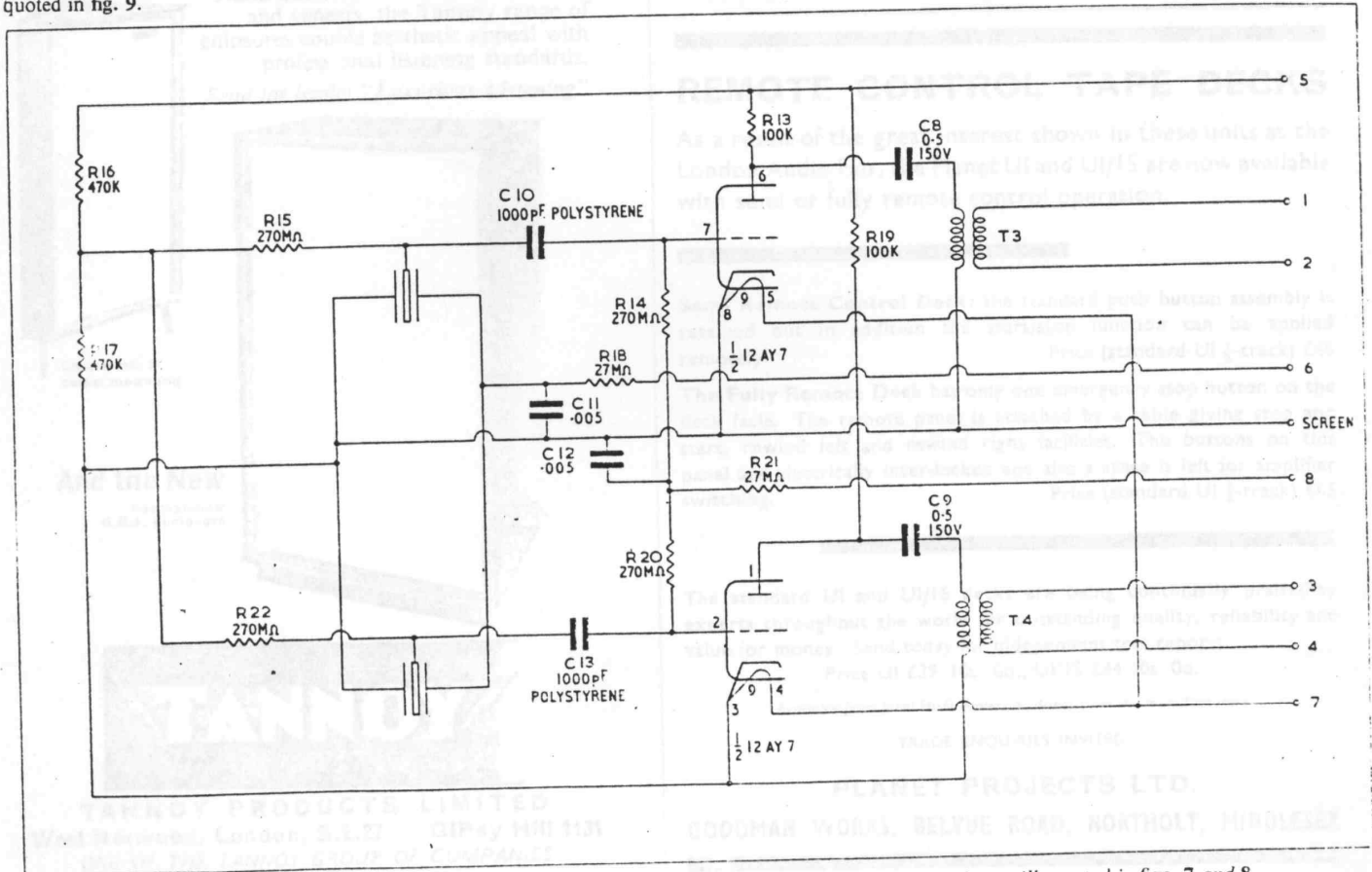

Fig. 5. Head pre-amplifier for the stereo microphone. This is all mounted beneath the capsules as illustrated in figs. 7 and 8

As a result of a talk given by the authors to the Cambridge University Tape Recording Society, some six people now possess similar microphones, in the monophonic version, and it should be mentioned that they are all very closely matched in performance. For anyone with moderate skill on a lathe, or an enthusiastic engineering friend, the project should present no difficulties. The end-product is a microphone which has been found to perform favourably in direct comparison with similar, but expensive, commercial units on the market today.

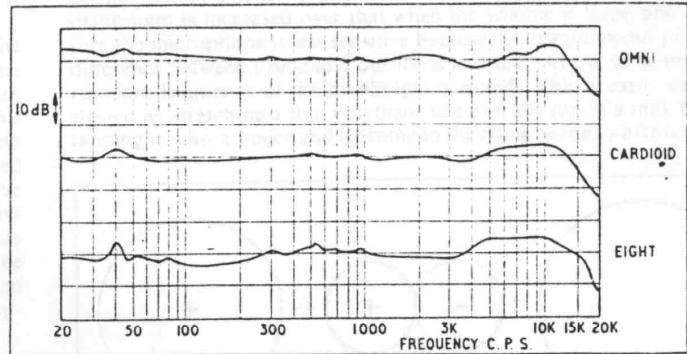

Fig. 10. Measured response of the microphone for three directional conditions. These curves make full allowance for the calibration curve of the measuring apparatus, and therefore represent the actual responses in each case

We hope to describe in a later article the techniques and problems in using the microphone for stereo recording of musical groups of various sizes, and to give a more detailed assessment of the performance in terms of subjective musical impressions. One final point: the Melinex sheet flashed with aluminium on both sides, as used for the diaphragms, is supplied by Geo. M. Whiley Ltd., 54 Whitfield Street, London, W.1.

REMOTE CONTROL TAPE DECKS

As a result of the great interest shown in these units at the London Audio Fair, the Planet UI and UI/15 are now available with semi or fully remote control operation.

Semi Remote Control Deck: the standard push button assembly is retained but in addition the start/stop function can be applied remotely. Price (standard UI ½-track) £48

The Fully Remote Deck has only one emergency stop button on the deck facia. The remote panel is attached by a cable giving stop and start, rewind left and rewind right facilities. The buttons on this panel are electrically inter-locked and also a space is left for amplifier switching. Price (standard UI ½-track) £65

The standard UI and UI/15 decks are being continually praised by experts throughout the world for outstanding quality, reliability and value for money. Send today for independent test reports.

Price UI £39 10s. 0d., UI/15 £44 10s. 0d.

Available from local Hi-Fi dealers or direct from the manufacturers

TRADE ENQUIRIES INVITED

PLANET PROJECTS LTD.

GOODMAN WORKS, BELVUE ROAD, NORTHOLT, MIDDLESEX

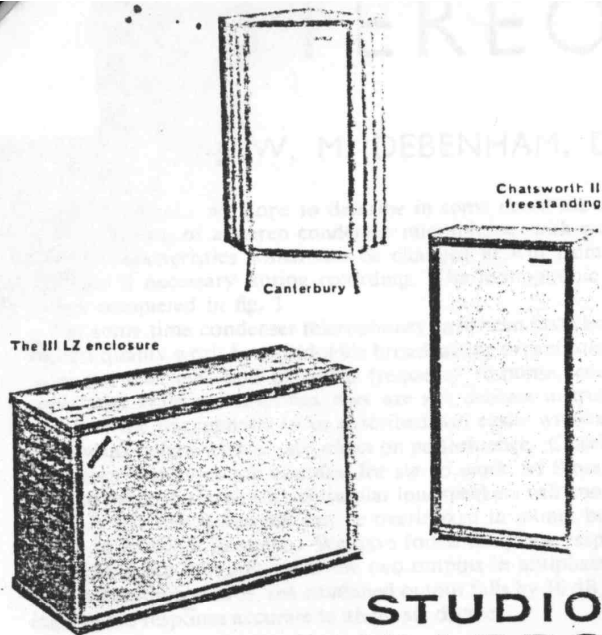

STUDIO STANDARDS

in your home

TANNOY DUAL CONCENTRIC loudspeakers and enclosures have become accepted standards of quality. Hand built from selected hardwoods and veneers, the Tannoy range of enclosures couple aesthetic appeal with professional listening standards. Send for leaflet "Luxurious Listening"

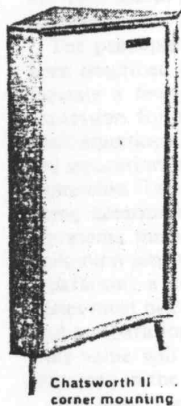

Chatsworth II corner mounting

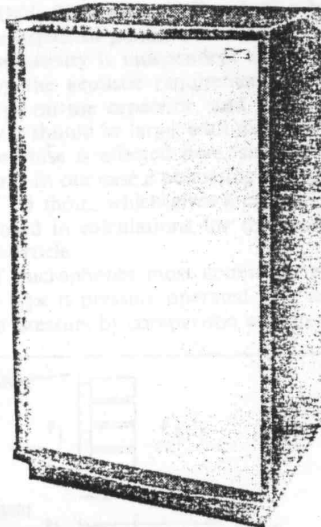

And the New freestanding G.R.F. enclosure



TANNOY PRODUCTS LIMITED
West Norwood, London, S.E.27 GIPsy Hill 1131
ONE OF THE TANNOY GROUP OF COMPANIES